

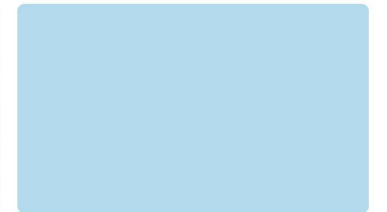

MAGNET FOREVER
Professional, Energy saving, Green

XIAMEN MAGNET FOREVER ELECTRONIC CO., LTD.
Office Address: Room 403, ZhongDa E-Business Park, No.39 Xinchang Road, Hai Cang District, Xi amen, Fuj ian,
Chi na 361026
Tel : +86-592-6518969
Fax : +86-592-5735297
E-Mai l : sales@magforever.com

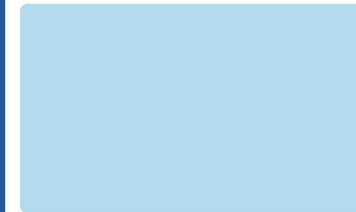



OUR COMPANY

1

Xi amen magnet forever electronic co. , l t d . is a profes- sional engaged in the research, development, sale and service of Pot Magnet, Fishing Magnet, Magnetic Hook, Retaining Magnet, Neodymium Magnet.

We are located in Ningbo City with convenient trans- portation access. Dedicated to strict quality control and thoughtful customer service, our experienced staff members are always available to discuss your require- ments and ensure full customer satisfaction. Selling well in all cities and provinces around China, our products are also exported to clients in such countries and re- gions as North America, Western Europe, Eastern Europe, Northern Europe, East Asia .

We also welcome OEM and ODM orders. Whether selecting a current product from our catalog or seeking engineering assistance for your application, you can talk to our customer service center about your sourcing requirements.

PRODUCT DISPLAY



PRODUCT DISPLAY

2

ALL KINDS OF NDFEB MAGNETIC PRODUCTS

- NDFEB MAGNET
- NEODYMIUM POT MAGNET
- NEODYMIUM MAGNETIC HOOK
- FISHING MAGNET
- RUBBER COATED MAGNET
- OTHER MAGNETIC PRODUCTS

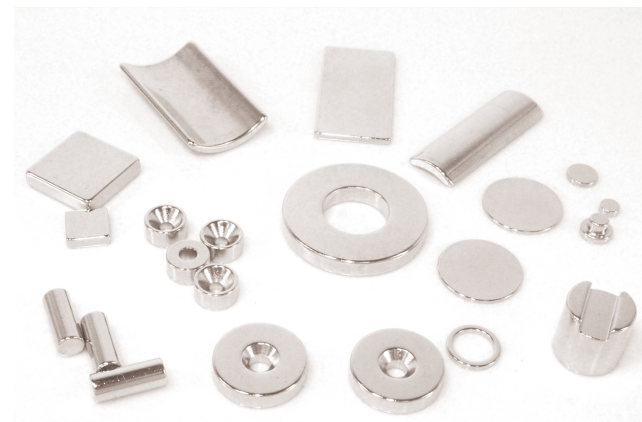
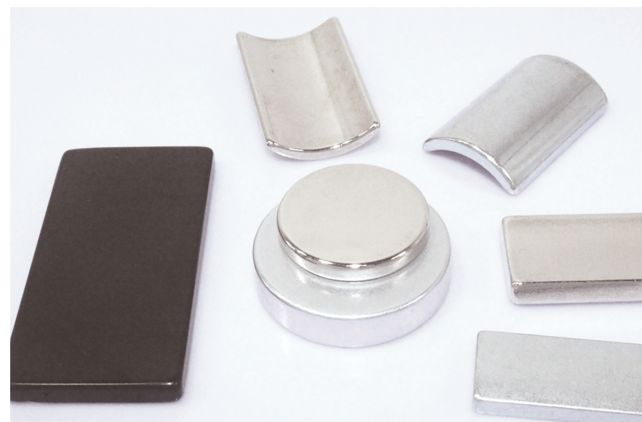

NDFEB MAGNETS

PRODUCT CHARACTERISTICS

Sintered neodymium iron boron magnets are the most commonly used rare earth magnets. They are the strongest permanent magnets today. They are called "magnet kings" because of their excellent magnetic properties.

Sintered NdFeB magnets not only have the characteristics of high remanence, high coercivity, high energy product, and high cost performance, but can be processed into various shapes, such as square, cylinder, ring, tile and other shapes.

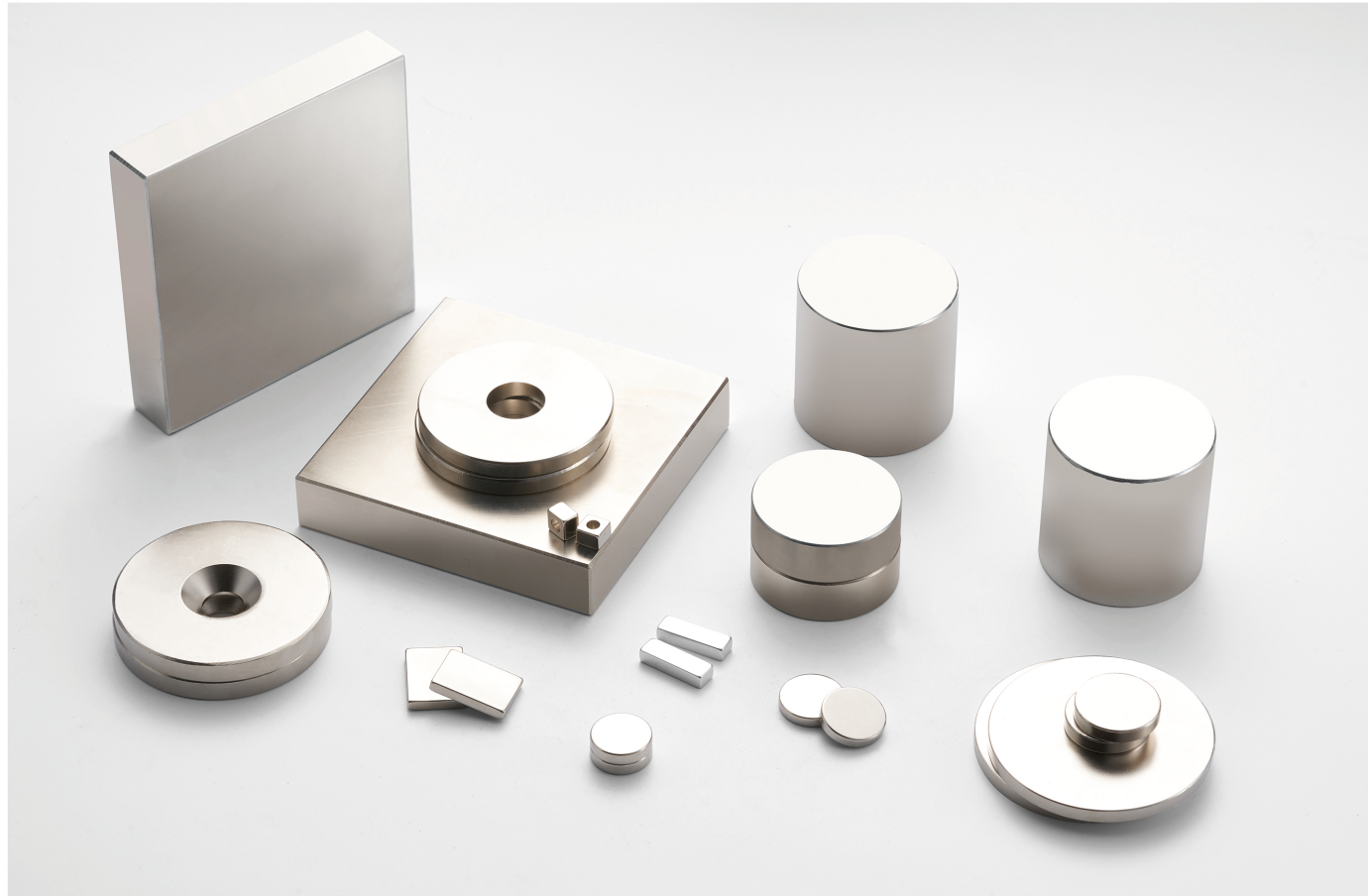

1-Disc Magnet

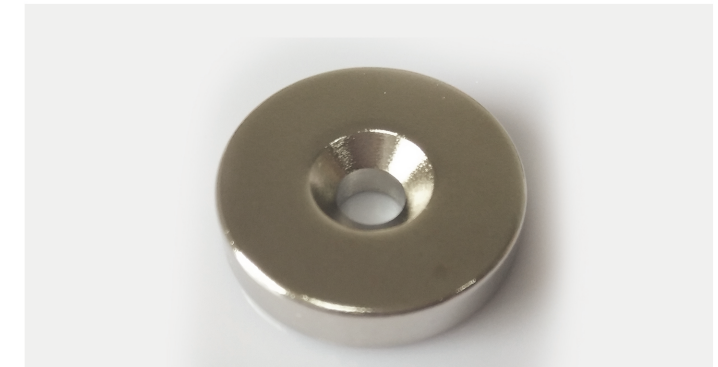

2-Disc Magnet with Countersunk Hole



3-Tile Shape magnet



4-Square Magnet

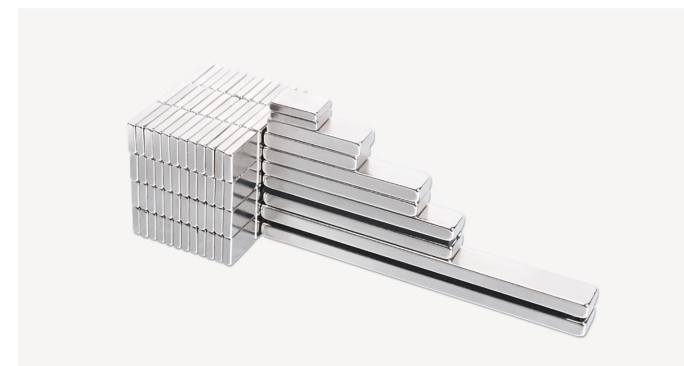

5-Bar Magnet



6-Ring Magnet

Sintered NdFeB Magnet-Magnetic Performance Table (1)

Grade	Remanence		Intrinsic Coercivity		Coercivity		Maximum Energy product		Maximum Operating	
	(Br)		(Hc)		(Hci)		(BHmax)		Temperature	
	(Gs)	(mT)	(Oe) min	(kA/m) min	(kOe) min	(kA/m) min	(MGOe)	(KJ/m ³)	(°C)	(°F)
N30	10800	1080	9800	780	12	955	30	239	80	176
N33	11400	1140	10300	820	12	955	33	263	80	176
N35	11700	1170	10800	860	12	955	35	279	80	176
N38	12200	1220	10800	860	12	955	38	303	80	176
N40	12600	1260	10500	836	12	955	40	318	80	176
N42	12600	1260	10500	836	12	955	42	342	80	176
N45	13300	1330	10500	923	12	836	45	358	80	176
N48	13700	1370	10500	923	12	836	48	382	80	176
N50	14000	1400	10500	836	12	955	51	406	80	176
N52	14200	1420	10500	836	11	876	53	422	80	176
N30M	10800	1080	10200	816	14	1114	30	239	100	212
N33M	11400	1140	10700	852	14	1114	33	263	100	212
N35M	11700	1170	11000	876	14	1114	35	279	100	212
N38M	12200	1220	11500	916	14	1114	38	303	100	212
N40M	12600	1260	11800	939	14	1114	40	318	100	212
N42M	12900	1290	12000	955	14	1114	42	334	100	212
N45M	13200	1320	12400	987	14	1114	46	366	100	212
N48M	13700	1370	12800	1018	14	1114	49	390	100	212
N50M	13900	1390	13200	1050	14	1114	51	406	100	212
N30H	10800	1080	10200	812	17	1353	30	239	120	248
N33H	11400	1140	10700	851	17	1353	33	263	120	248
N35H	11700	1170	11000	875	17	11353	35	279	120	248

Sintered NdFeB Magnet-Magnetic Performance Table (2)

Grade	Remanence		Intrinsic Coercivity		Coercivity		Maximum Energy product		Maximum Operating	
	(Br)		(Hc)		(Hci)		(BHmax)		Temperature	
	(Gs)	(mT)	(Oe) min	(kA/m) min	(kOe) min	(kA/m) min	(MGOe)	(KJ/m ³)	(°C)	(°F)
N38H	12200	1220	11600	916	17	1353	38	303	120	248
N40H	12600	1260	11800	939	17	1353	40	318	120	248
N42H	12900	1290	12000	955	17	1353	42	334	120	248
N45H	13200	1320	12400	987	17	1353	46	366	120	248
N48H	13600	1360	12700	1011	16	1273	49	390	120	248
N50H	14000	1400	12900	1011	16	1273	51	406	120	248
N30SH	10800	1080	10200	812	20	1592	30	239	150	302
N33SH	11400	1140	10700	851	20	1592	33	263	150	302
N35SH	11700	1170	11000	876	20	1592	35	279	150	302
N38SH	12200	1220	11300	899	20	1592	38	303	150	302
N40SH	12600	1260	11700	931	20	1592	40	318	150	302
N42SH	12900	1290	12100	963	20	1592	42	334	150	302
N44SH	13000	1300	12300	979	20	1592	45	358	150	302
N28UH	10400	1040	9800	780	25	1990	28	223	180	356
N30UH	10800	1080	10100	804	25	1990	30	239	180	356
N33UH	11400	1140	10300	875	25	1990	33	263	180	356
N35UH	11700	1170	10800	860	25	1990	35	279	180	356
N38UH	12200	1220	11400	908	25	1990	38	303	180	356
N40UH	12600	1260	11800	940	25	1990	40	319	180	356
N26EH	10000	1000	9600	764	30	2388	26	207	200	392
N28EH	10400	1040	9800	780	30	2388	28	223	200	392
N30EH	10800	1080	10100	804	30	2388	30	239	200	392
N33EH	11200	1120	10400	828	30	2388	33	263	200	392
N35EH	11700	1170	10800	860	30	2388	36	287	200	392

NEODYMIUM POT MAGNETS

Model: A
Cup / Countersunk Hole

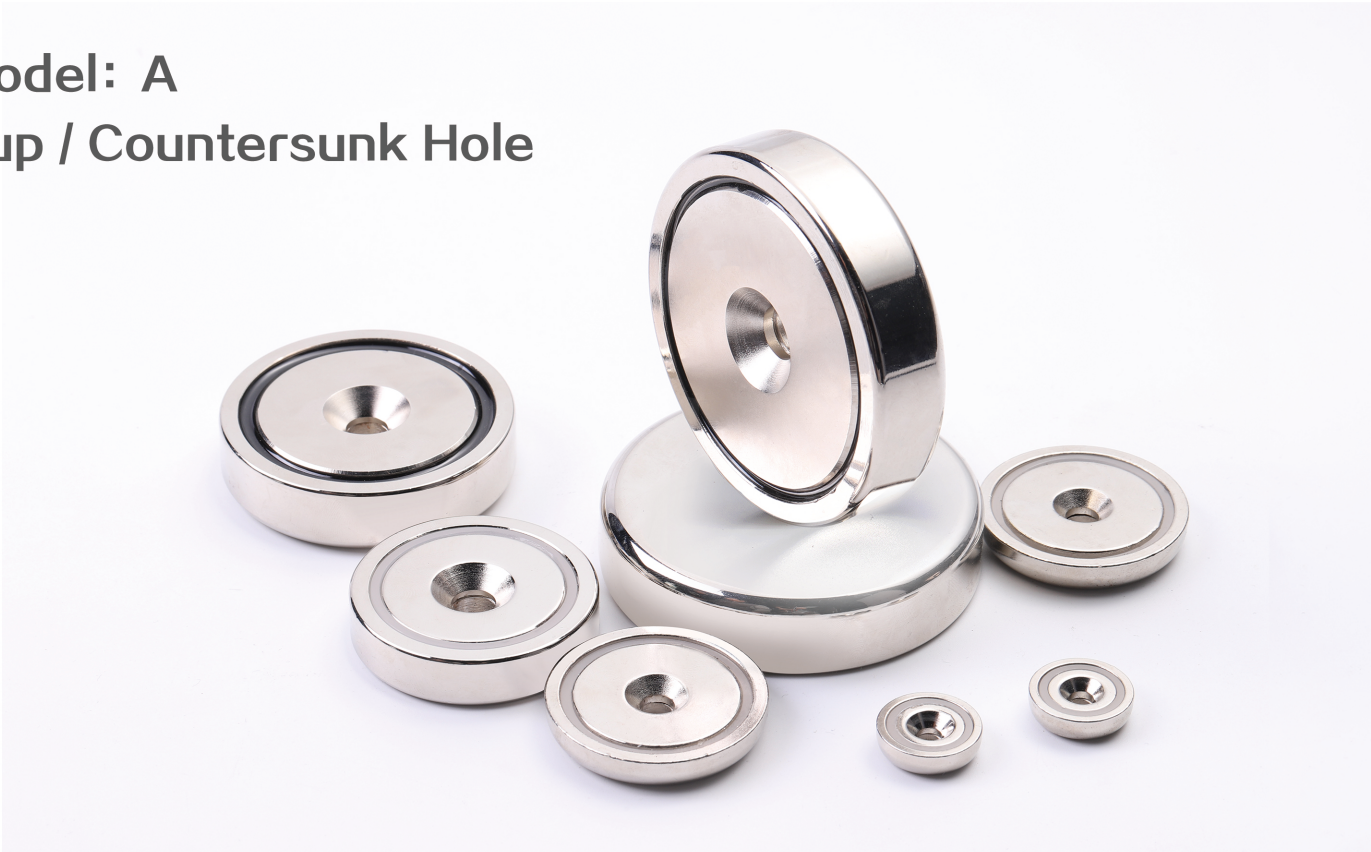

Model	Size (mm)				Hole Degree	strength (Kg)
	D	D1	D2	H		
A16	16	3.5	6.5	5	90°	5
A20	20	4.5	8.6	7	90°	6
A25	25	5.5	10.5	8	90°	14
A32	32	5.5	10.5	8	90°	25
A36	36	6.5	12	9	90°	29
A42	42	6.5	12	9	90°	37
A48	48	8.5	16	11.5	90°	68
A60	60	8.5	16	15	90°	112
A75	75	10.5	20	18	90°	162
A90	90	10.5	20	18	90°	300
A120	120	12.5	20.5	18	90°	600

- Material: Steel case, NdFeB magnet, pvc ring/epoxy glue

- Coating: Nickel-Magnetizing direction: Axially

- Maximum working temperature: +80°C

- A type Neodymium Pot Magnet has a countersunk hole in the middle, which can be used with countersunk screws, The screw is used and fixed on the equipment, furniture, wall and other places.

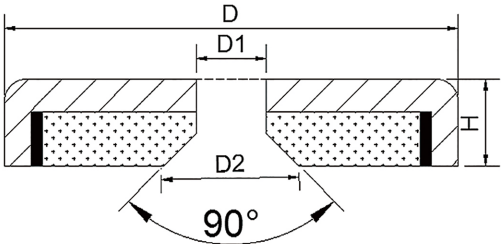

Model: B
Cup / Counterbore Hole



Model	Size (mm)				strength (Kg)
	D	D1	D2	H	
B16	16	3.5	6.5	5	4
B20	20	4.5	8	7	6
B25	25	5.5	9	8	14
B32	32	5.5	9	8	23
B36	36	6.5	11	9	29
B42	42	6.5	11	9	32
B48	48	8.5	15	11.5	63
B60	60	8.5	15	15	95
B75	75	10.5	18	18	155

- Material: Steel case, NdFeB magnet, pvc ring/epoxy glue

- Coating: Nickel-Magnetizing direction: Axially

- Maximum working temperature: +80°C

- There is a Counterbore hole in the middle of the B-type Neodymium Pot magnet, which can be used with screws and screws with cylindrical head, pan head, spherical column head, half round head, oblate head, and fixed on equipment, furniture and walls.

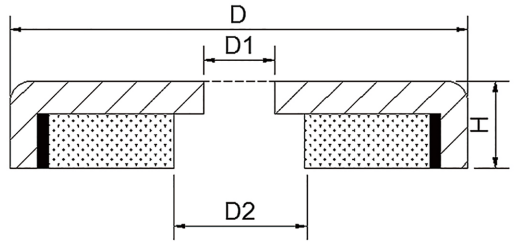

Model: C
external thread



Model: D
Female thread



Model	Size (mm)				Strength (Kg)
	D	M	H	h	
C10	10	3	13	4	3
C12	12	4	12	5	4
C16	16	4	13	5	5.5
C20	20	4	15	7	9
C25	25	5	17	8	22
C32	32	6	18	8	34
C36	36	6	18	8	41
C42	42	8	20	9	68
C48	48	8	24	11.5	81
C60	60	8	30	15	113
C75	75	10	34	18	164
C80	80	10	34	18	250
C90	90	10	34	18	300
C100	100	12	35	18	400
C120	120	12	35	18	500
C136	136	16	38	20	600

- Material: steel case, NdFeB magnet, pvc ring/epoxy glue
- Coating: Nickel-Magnetizing direction: Axially
- Maximum working temperature: +80°C
- The C-shaped Neodymium magnetic hook is equipped with an external thread post, which can be used with the corresponding screw holes to be fixed on the equipment, furniture and walls.

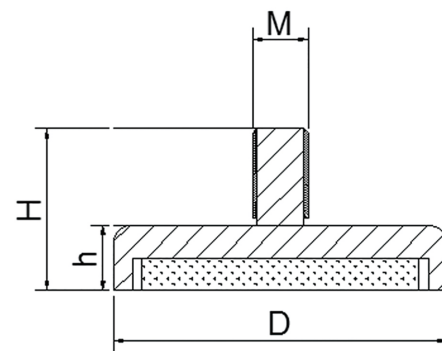

Model	size (mm)					Strength (Kg)
	D	D1	M	H	h	
D10	10	6	3	12	4	3
D12	12	6	4	12	5	4
D16	16	6	4	13	5	5.5
D20	20	8	4	15	7	9
D25	25	10	5	17	8	22
D32	32	10	6	18	8	34
D36	36	10	6	18	8	41
D42	42	12	8	20	9	68
D48	48	12	8	24	11.5	81
D60	60	14	8	30	15	113
D75	75	16	10	34	18	164

- Material: Steel case, NdFeB magnet, pvc ring/epoxy glue
- Coating: Nickel-Magnetizing direction: Axially
- Maximum working temperature: +80°C
- The D-type Neodymium magnetic hook is equipped with an internal threaded stud, which can be used with a screw to be fixed on equipment, furniture and other places.

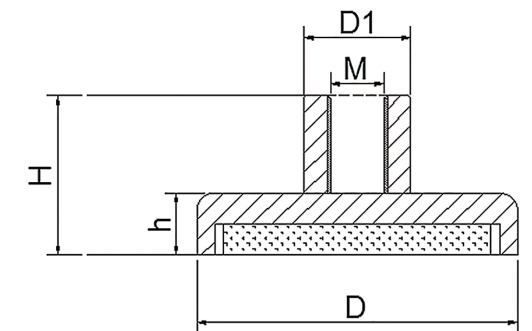

**Model: E
hook**



**Model: Y
eyelet**



Model	Size (mm)					Strength (Kg)
	D	D1	M	H	h	
E10	10	6	3	12	4	3
E12	12	6	4	12	5	4
E16	16	6	4	13	5	5.5
E20	20	8	4	15	7	9
E25	25	10	5	17	8	22
E32	32	10	6	18	8	34
E36	36	10	6	18	8	41
E42	42	12	8	20	9	68
E48	48	12	8	24	11.5	81
E60	60	14	8	30	15	113
E75	75	16	10	34	18	164

- Material: Steel case, NdFeB magnet, pvc ring/epoxy glue
- Coating: Nickel-Magnetizing direction: Axially
- Maximum working temperature: +80°C
- The E-type NdFeB magnetic hook is equipped with a hook on the iron shell, which can attract the magnetic hook sucker to the iron interface for lifting objects.

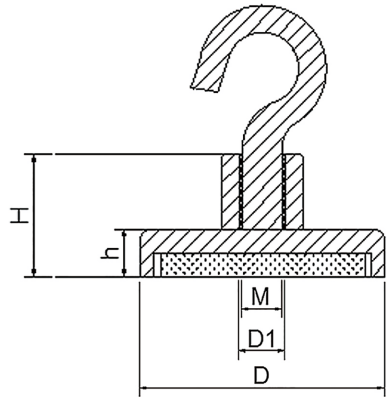

Model	Size (mm)					Strength (Kg)
	D	D1	M	H	h	
Y12	12	6	4	12	5	4
Y16	16	6	4	13	5	5.5
Y20	20	8	4	15	7	9
Y25	25	10	5	17	8	22
Y32	32	10	6	18	8	34
Y36	36	10	6	18	8	41
Y42	42	12	8	20	9	68
Y48	48	12	8	24	11.5	81
Y60	60	14	8	30	15	113
Y75	75	16	10	34	18	164

- Material: Steel case, NdFeB magnet, pvc ring/epoxy glue
- Coating: Nickel-Magnetizing direction: Axially
- Maximum working temperature: +80°C
- The Y-shaped NdFeB magnetic hook is equipped with eyelet, which can be used with safety buckles and ropes for salvaging purposes.

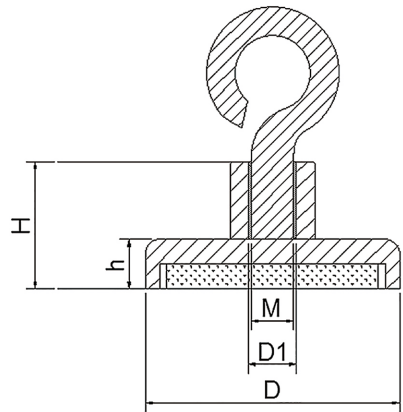

Model: RS
inner thread



Model: BP
block with countersunk hole



Model	Size (mm)				Strength (Kg)
	D	d	M	H	
RS16	16	6	4	5	4
RS20	20	6	4	6	6
RS25	25	10	5	7	14
RS32	32	10	5	7	25
RS36	36	10	6	7.3	29
RS42	42	12	6	7.5	37
RS48	48	12	8	11.5	68
RS60	60	14	8	15	120
RS75	75	16	10	18	165
RS80	80	16	10	18	220
RS94	94	16	10	20	270
RS116	116	20	12	22	350
RS136	136	20	12	25	500

- Material: steel case, NdFeB magnet, pvc ring/epoxy glue
- Coating: Nickel-Magnetizing direction: Axially
- Maximum working temperature: +80°C
- The RS-type NdFeB Pot magnet is equipped with a inner thread in the middle, which can be used with a screw to be fixed on equipment, furniture and walls.

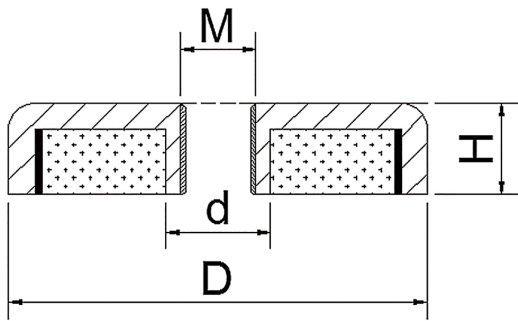

Model	L (mm)	L1 (mm)	W (mm)	H (mm)	D1 (mm)	D2 (mm)	Vertical Suction (Kg)
BP10	10	5	13.5	5	3.3	6.5	4
BP15	15	7.5	13.5	5	3.3	6.5	7
BP20	20	10	13.5	5	3.3	6.5	8
BP30	30	15	13.5	5	3.3	6.5	16
BP40	40	30	13.5	5	3.3	6.5	17
BP50	50	40	13.5	5	3.3	6.5	27
BP60	60	50	13.5	5	3.3	6.5	28
BP80	80	70	13.5	5	3.3	6.5	33
BP100	100	90	13.5	5	3.3	6.5	36
BP120	120	110	13.5	5	3.3	6.5	40

- Material: steel case, NdFeB magnet, pvc ring/epoxy glue
- Coating: Nickel-Magnetizing direction: Axially
- Maximum working temperature: +80°C
- There are countersunk holes in the magnet, which can be used with countersunk screws and screw rods, and can be fixed on the equipment, wall and other places.

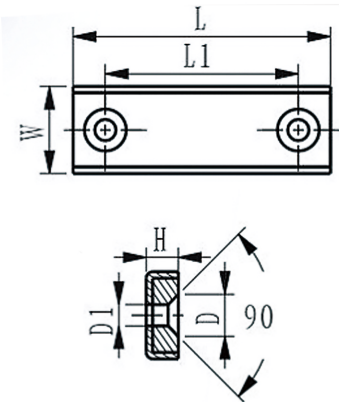

SUPER STRONG FISHING MAGNETS

Model: AH
Countersunk hole+eyebolt



Model	Size (mm)					Strength (Kg)
	D	D1	D2	H	h	
AH20	20	4	8.6	26	7	6
AH25	25	5	10.5	31	8	14
AH32	32	5	10.5	31	8	25
AH36	36	6	12	41	9	29
AH42	42	6	12	41	9	37
AH48	48	8	16	47.5	11.5	68
AH60	60	8	16	54	15	112
AH75	75	10	20	66	18	162
AH90	90	10	20	66	18	300
AH120	120	12	25	74	18	600

- Material: steel case, NdFeB magnet, pvc ring/epoxy glue
- Coating: Nickel-Magnetizing direction: Axially
- Maximum working temperature: +80°C
- There is a countersunk hole in the middle of the AH magnetic fish catcher, equipped with a screw rod and a eyebolt.

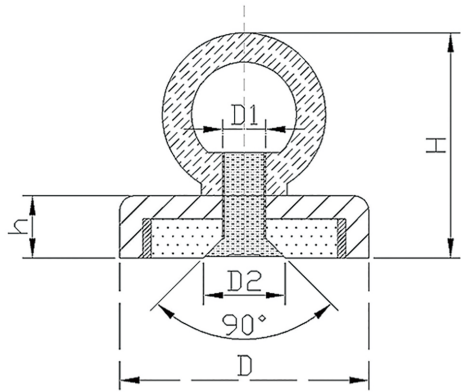

Model: H
eyebolt



Model	Size (mm)				Strength (Kg)
	D	M	H	h	
H20	20	4	26	7	9
H25	25	5	31	8	22
H32	32	6	37	8	34
H36	36	6	37	8	41
H42	42	8	48	9	68
H48	48	8	50.5	11.5	81
H60	60	8	54	15	113
H75	75	10	66	18	164
H80	80	10	66	18	250
H90	90	10	66	18	300
H100	100	12	74	18	400
H120	120	12	74	18	500
H136	136	16	86	20	600

- Material: steel case, NdFeB magnet, pvc ring/epoxy glue
- Coating: Nickel-Magnetizing direction: Axially
- Maximum working temperature: +80°C

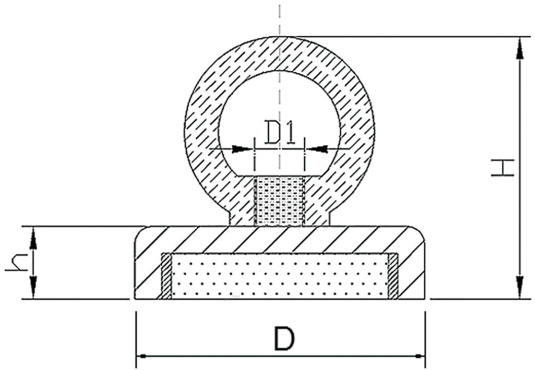

Model: F
Double-sided fishing magnet



Model	Size (mm)			Strength (Kg)
	D	H	M	
F48	48	18	8	100
F60	60	22	8	120
F75	75	25	10	200
F94	94	28	10	300
F116	116	32	12	400
F136	136	34	12	500

- Material: steel case, eyelet, NdFeB magnet and epoxy resin glue
- NdFeB magnet shape: cylinder
- Number of NdFeB magnets: 2 pieces
- Magnetizing direction: through thickness
- Product coating: nickel
- Epoxy color: black
- Maximum working temperature: +80°C

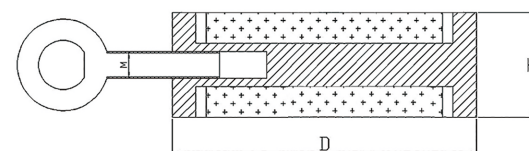

Model: DS
Double-sided fishing magnet



Model	Size (mm)			Strength (Kg)
	D	H	M	
DS48	48	25	8	100*2
DS60	60	30	8	120*2
DS75	75	32	10	200*2
DS94	94	32	10	300*2
DS116	116	34	12	400*2
DS136	136	34	14	600*2

- Material: steel case, eyebolt, NdFeB magnet and epoxy resin glue
- NdFeB magnet shape: ring
- Number of NdFeB magnets: 2 pieces
- Magnetizing direction: through thickness
- Product coating: nickel
- Epoxy color: black
- Maximum working temperature: +80°C
- Both the upper and lower sides of the double-sided magnetic fishing device are magnetic contact surfaces, which can adsorb iron objects.

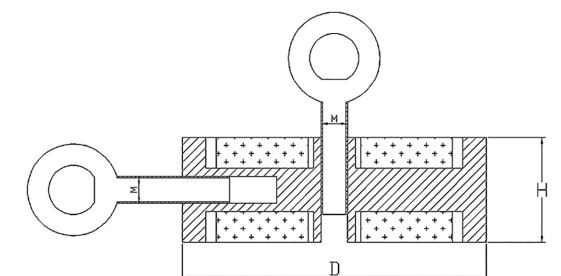

RUBBER COATED MAGNET SERIES

Model: TT
inner thread

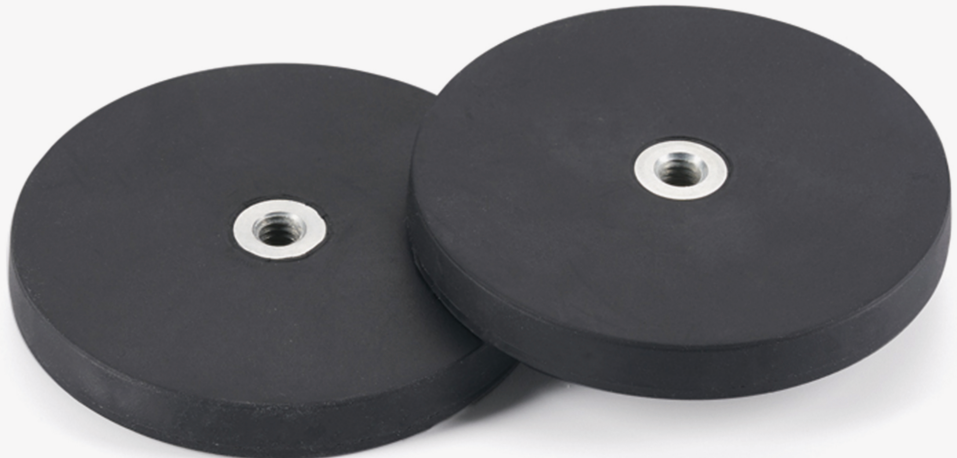

Model	Diameter D (mm)	Thickness H (mm)	Strength (Kg)
TT22	22	6	3
TT43	43	6	8.5
TT66	66	8.5	18
TT88	88	8.5	42

- Material: NdFeB magnet, steel base, rubber coat
- Rubber color: black
- TT-type rubber-coated magnets are equipped with inner threaded hole, which can be used with screw
- Model TT43 coated magnet can be equipped with a handle for easy removal
- Rubber coated magnet can be used for car film

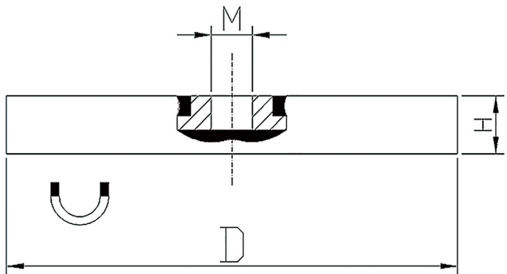

Model: AC
female thread stud



Model	Diameter D (mm)	Thickness H (mm)	Height L (mm)	Strength (Kg)
AC22	22	6	13.5	3
AC43	43	6	10.5	8.5
AC66	66	8.5	15.5	18
AC88	88	8.5	19	42

- Material: NdFeB magnet, steel base, rubber coat
- Rubber color: black
- TT-type rubber-coated magnets are equipped female thread stud, which can be used with screw
- Model TT43 coated magnet can be equipped with a handle for easy removal
- The coated magnet can be used for car film

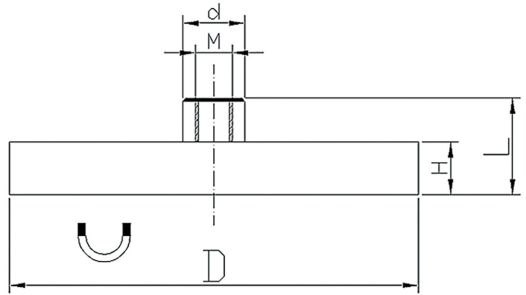

OTHER MAGNETIC PRODUCTS

Model: TF
external threaded rod

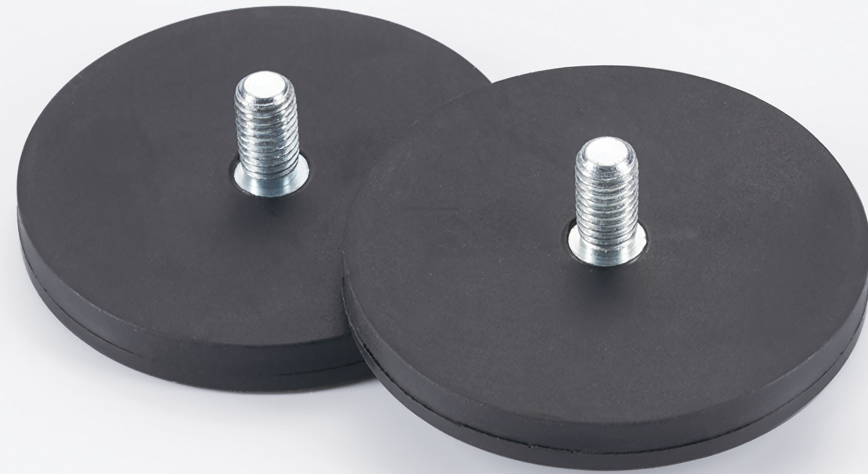

Model: X



Model	Diameter D (mm)	Thickness H (mm)	Height L (mm)	Strength (Kg)
TF22	22	6	13.5	3
TF43	43	6	21	8.5
TF66	66	8.5	23	18
TF88	88	8.5	24	42

- Material: NdFeB magnet, steel base, rubber coat
- Rubber color: black
- The rubber-coated magnets are equipped with an external threaded rod, which can be used with a threaded groove to make it fixed.

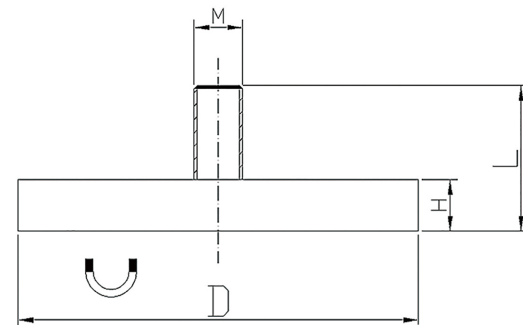

Model	D (mm)	A (mm)	B (mm)	C (mm)	H (mm)	L (mm)	Vertical Suction (g)	Horizontal suction (g)
X25	25	17	13.5	22	14.5	52	16	2
X32	32	17	13.5	25	14.5	54	30	3
X36	36	20	13.5	25	15.5	54	41	5
X42	42	30	13.5	25	16.5	54	60	8

- Material: steel case, rotating hook, NdFeB magnet and pvc ring
- Coating: Nickel
- Magnetizing direction: Axially
- Maximum working temperature: +80°C
- The X-shaped magnetic rotating hook can be used for attracting to suck on the iron interface, which is used to lift accessories, and put objects in the book, office and home.

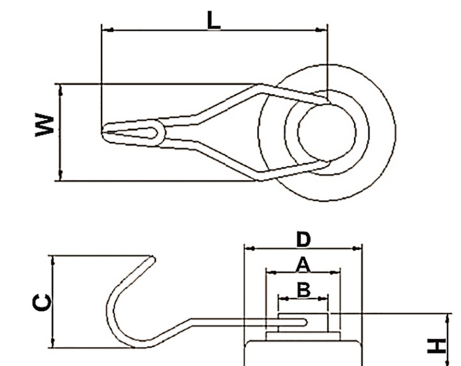

BUSINESS APPLICATION FIELD



◀ 1 ▲ 2 ○ 3
Widely used in IT, communi-
cations, automatic control,
transportation, home appli-
ances, motors, scientific re-
search and other fields.
○ 6 ▼ 5 ▲ 4

